



3312^{Q&As}

Avaya Aura Contact Center Administration Exam

Pass Avaya 3312 Exam with 100% Guarantee

Free Download Real Questions & Answers **PDF** and **VCE** file from:

<https://www.passapply.com/3312.html>

100% Passing Guarantee
100% Money Back Assurance

Following Questions and Answers are all new published by Avaya
Official Exam Center

-  **Instant Download** After Purchase
-  **100% Money Back** Guarantee
-  **365 Days** Free Update
-  **800,000+** Satisfied Customers





QUESTION 1

A customer wants to measure the system-wide Contact Center traffic, not just traffic on an individual skillset or application basis.

Which category of intrinsic would provide this information?

- A. Open Queue
- B. Traffic
- C. Call
- D. Time

Correct Answer: D

QUESTION 2

A customer with Avaya Aura Contact Center (AACC) needs to create a new Contact Center Management supervisor in a SIP environment? Which field is mandatory for a Contact Center Management supervisor in a SIP environment?

- A. Password
- B. Language
- C. Skillset
- D. Login ID
- E. Call Presentation Class

Correct Answer: D

QUESTION 3

Refer to the exhibit.

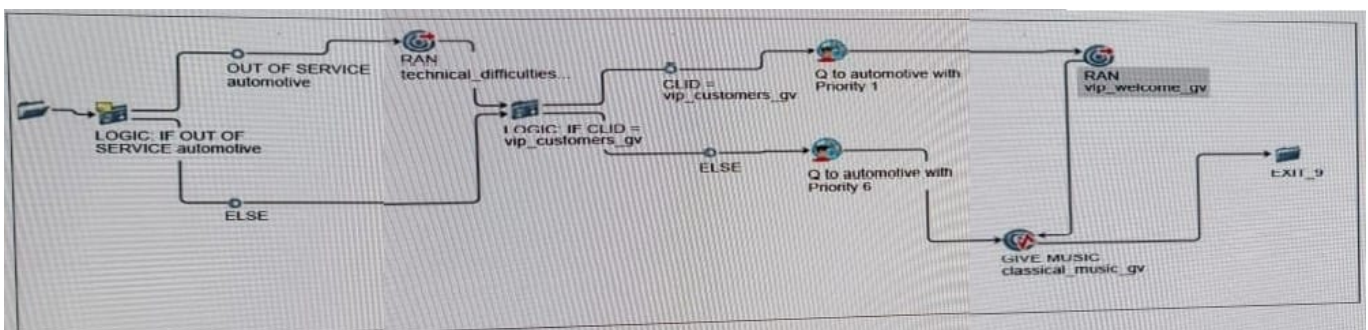



The flow in the exhibit has been created in Avaya Aura Contact Center (AACC) Orchestration Designer Scripting. If the automotive skillset is out of service, the caller will hear a technical difficulties announcement, and then proceed to the Logic Block. After the technical difficulties announcement, the caller should be disconnected.

To provide a disconnect, to which block should the technical difficulties output block be connected?

- A. Finish Block
- B. Custom Block
- C. Treatment Block
- D. Anchor Block

Correct Answer: D

QUESTION 4

Which statement regarding scripts is true?

- A. A primary script is the only place that call variables can be assigned.
- B. A secondary script is the only place treatments can be applied to the call.
- C. A primary script is referenced directly from the Master script, otherwise it is a secondary script.
- D. Only a single secondary script allowed per application.

Correct Answer: C

QUESTION 5

From which area of the Avaya Agent Desktop can you copy the Customer CLID?

- A. Customer Basic Tab
- B. Customer Intrinsic Tab
- C. Customer Detail Tab
- D. Customer Contact Tab

Correct Answer: B

[Latest 3312 Dumps](#)

[3312 Practice Test](#)

[3312 Brainsdumps](#)